

EC74/50S

365-Day Four Channel Time Control

I. INTRODUCTION

The EC74/50S is a 365-day, four channel, microprocessor-based time control. It is ideal for lighting or HVAC control in which time-of-day scheduling is common. The programmable momentary feature provides a 1 to 59 second momentary contact closure for applications such as bell ringing, urinal flushing, synchronous wall clock correction and operating mechanical latching relays. The enclosure is made of durable noncorrosive plastic for years of life.

II. SPECIFICATIONS

Programming Capabilities

- Seven-day programming using 365-day calendar with eighth day as a holiday program.
- 16 holiday durations programmable by date.
- 50 set points. A set point can be assigned to any day or to any combination of days. Each of the 4 circuits can be independently programmed.
- Each set point can be either an ON, OFF or momentary type event. A programmable momentary duration of 1-59 seconds can be entered for each of the 4 circuits.
- 12-hour (A.M./P.M.) or 24-hour clock format.
- Automatic daylight-saving time changeover with yearly compensation.
- Keyboard override until next programmed event.
- 3-second stagger up between loads.
- Leap year corrected.
- Keyboard programming.
- LCD display of time-of-day and day of week. Circuit status indicated by LEDs (if LED is lit, output relay is energized as a result of a programmed ON or an override).

Electrical

Power Requirements:

Input Power (three voltage models):

24 Vac (+10-15%), 50/60 Hz

100-120 Vac (+10-15%), 50/60 Hz

200-240 Vac (+10-15%), 50/60 Hz

4 SPDT Output Relay Contacts:

VOLTAGE	RESISTIVE	H.P.	PILOT DUTY
24 Vac	10A	1/10	60 VA
120 Vac	7.5A	1/3	345 VA
240 Vac	5A	1/2	360 VA

Wiring: Terminals can accommodate 12 to 24 AWG wire.

Power Outage Carryover

Program and Time-of-Day Back Up-100 hours of carryover with 9 volt alkaline battery (not provided).

- This control is completely operational during a power outage, except for relay operation.

Accuracy

Time-of-day-Maintained time is as accurate as line frequency.

Resolution-One minute for time-of-day and programmed ON and OFF events. (One second resolution using momentary type event.)

Physical

Dimensions: Height 8.5 in. (21.6 cm)
Width 6.3 in. (16 cm)
Depth 3.8 in. (9.6 cm)

Weight: Approximately 1.6 lbs. (.7 kg)

Enclosure: NEMA type 3R plastic case.
Conduit knockouts.

Mounting: Vertical

Environment

Temperature: Operating-32 degrees F (0 degrees C) to 122 degrees F (50 degrees C)

Storage-0 degrees F (-20 degrees C) to 140 degrees F (60 degrees C)

III. INSTALLATION INSTRUCTIONS

Mount the control in an environment that is free from excessive contaminants such as oil, moisture, or dirt.

EC74/50S Mounting

1. Remove control from case by pushing outward the two clips on the left and right within case, and carefully lift control out.
2. Mount case in a vertical position using mounting holes provided (see Figure 1).
3. Replace control into case by sliding control under tabs at the top of the case. Push down and clips snap into place.

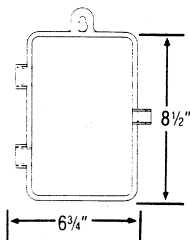

Figure 1.

Dimensions of EC74/50S

Conduit Connections:

1. Remove desired center knockouts by placing screwdrivers on inner ring groove by the arrow (see figure 2), then carefully apply a solid rap on the handle of the screwdriver with hand or hammer.
2. Remove outer ring, if necessary, by placing screwdriver into groove by the arrow (see figure 2) and punch inward. Smooth the opening's rim with round file or knife.
3. Attach conduit connector first to the conduit, then attach the conduit connector to the knockout hole using the connector lock nut. To prevent unnecessary stress on enclosure walls, conduit should be aligned and supported.

Wiring:

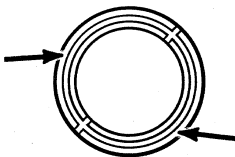

Figure 2. Knockouts

1. Wire 24, 120 or 240 Vac to input terminals, depending on the model selected. Terminals can accommodate 12 to 24 AWG wire. CAUTION: Damage will occur to unit if incorrect voltage is applied. Application of incorrect input voltage will void warranty.
2. Connect output wiring as required for the particular application.
3. Install a 9V alkaline battery (not provided). Remove battery cover. See Figure 3 below. Snap battery into battery clip. Replace battery cover.
4. Maintenance-The EC74/50S has been carefully engineered for reliability and safety; therefore, the only maintenance required is to replace the 9V battery approximately every two years. A battery log is provided to write down battery replacement dates. Do not use any type of cleaning agent on the liquid crystal display or the front panel.

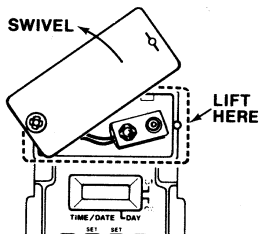

Figure 3. Battery Cover

IV. CONTROL DESCRIPTION

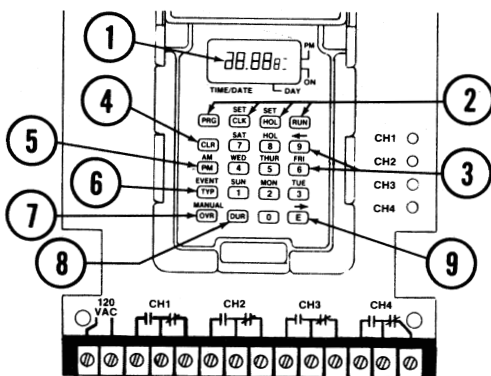

Figure 4. Front Panel

Front Panel

1. **Time/Date Indicator**-Displays hours and minutes in 12/24 hour format (for example, 00:00=midnight, 12:00=noon) or month and date for current day or an event being programmed or revised.
Day of Week Indicator-Displays current day of week or day being programmed. (Sunday=1, Monday=2, Saturday=7)
2. **Mode Keys**-PRG (program), CLK (clock), HOL (holiday), RUN used to select mode of operation.
3. **Number/Day Keys**-Used to select circuit number, and set or program time, day, date and year.
4. **Clear Key**-Must be used to clear an old entry before a new one may be entered and to clear keying errors.
5. **AM/PM Key**-Used to select 12-hour clock format and AM or PM in program and clock modes.
6. **Event TYP (type) Key**-Used to select ON, OFF, or momentary event type.
7. **Manual OVR (override) Key**-Used to toggle relay state until next event.
8. **DUR (duration) Key**-Used to program length of momentary pulses.
9. **E (enter) Key**-Used to enter a new set point and advances to allow review of program.

V. PROGRAMMING INSTRUCTIONS

The EC74/50S is easy to program. The sequence outlined here is the logical order of programming. First, you will want to program the time-of-day, day of week, date, and year. Then you can program set points according to your application (refer to Application Examples, Section VI for sample programming). You program the start time of the set point only, and you do not program the stop time. The starting of the next programmed set point terminates the present set point.

For your convenience, the control can be programmed without line power by using battery carryover. Relays, however, will not operate without line power.

NOTES:

1. When the unit is first powered, the display will show "24 Hr." Press the Enter key to select 24 hour format. Press the AM/PM key to select 12 hour format. (The display will change to midnight on Sunday with the period flashing.)
2. The unit's memory can be cleared by disconnecting line voltage and carryover battery.
3. For relay state to change, time must run through the set point starting time (for example, programming an 8:00 a.m. start time when it is already 9:00 a.m. will not change relay state); use override to change state immediately.
4. A zero must precede the hours, minutes, month and dates which are less than ten (Example-04/01 is April 1st).
5. The day of week is displayed as follows: 1=Sunday, 2=Monday, 3=Tuesday, 4=Wednesday, 5=Thursday, 6=Friday, 7=Saturday, and 8=Holiday.
6. In all programming modes, if a keying error is made, press CLR then reprogram entire sequence of number keys.

7.	24-Hour Clock Time	12-Hour Clock Time
	0:00	12:00 AM (Midnight)
	1:00	1:00 AM
	2:00	2:00 AM
	3:00	3:00 AM
	4:00	4:00 AM
	5:00	5:00 AM
	6:00	6:00 AM
	7:00	7:00 AM
	8:00	8:00 AM
	9:00	9:00 AM
	10:00	10:00 AM
	11:00	11:00 AM
	12:00	12:00 PM (Noon)
	13:00	1:00 PM
	14:00	2:00 PM
	15:00	3:00 PM
	16:00	4:00 PM
	17:00	5:00 PM
	18:00	6:00 PM
	19:00	7:00 PM
	20:00	8:00 PM
	21:00	9:00 PM
	22:00	10:00 PM
	23:00	11:00 PM

A. To Program Time, Day Of Week, Date, Year, And Daylight-Saving Time

NOTE: If in 12-hour clock format, P.M. is signified by a dash at the upper right of the display.

Step	Key	Description
1	CLK	Time and day of week on display vanish and dashes appear for each digit.
2	####	Key in time and day of week. If in 12-hour clock format, and in PM hours, press PM key; dash will appear at far right of display.
3	E	Enters time and day of week. Default date of January 1 appears.
4	CLR	Date vanishes and dashes appear for each digit.
5	####	Key in date. (Month is first and day is second in both 12-hour and 24-hour mode.)
6	E	Date is entered. Latest or default year is displayed.
7	CLR	Clears year.
8	##	Key in current year. Two keys must be pressed (i.e., "87").
9	E	Enters year. "SPr" appears (spring daylight-saving time).
10	###	Key in date (month/day) of spring daylight-saving time, if desired. (If not desired, proceed with step 11.)
11	E	Enters spring date. "FaLL" appears (fall daylight-saving time.)
12	####	Key in date of fall daylight-saving time, if desired. (If not desired, proceed with step 13.)
13	E	Enters fall date. Control returns to RUN mode.

B. To Review Date, Year, and Daylight-Saving Time

Step	Key	Description
1	CLK	Dashes appear for time and day of week.
2	E	Month and day appear.
3	E	Year appears.
4	E	Date of spring daylight-saving time appears.
5	E	Date of fall standard daylight time appears.

C. To Program Set Points

The EC74/50S offer three event choices: ON, OFF, or pulse (momentary contact) event. The EC74/50S has 50 set points assignable to any or all of the four channels.

NOTES:

1. A set point can be assigned to any single day or to any combination of days.
2. Programming a set point involves two stages: the first screen displays circuit (channel) number to be programmed and the second screen displays event type.
3. The "E" key serves as a forward advance key. The "9" serves as a reverse key.

Step	Key	Description
1	PRG	"cir" for first event is displayed, if no previous set points have been programmed (press E key to advance past previous programming.)
2	1, 2, 3 or 4	Key in circuit number.
3	E	Enters circuit number; "--.--" appears.
4	####	Key in time of event (and A.M./P.M. if necessary).
5	#	Key in day(s) of week and holiday if desired. If more than one day is desired, key in additional days. (Days programmed will flash on display in sequence.)

NOTE: A day already entered can be removed by pressing the number key representing that day.

- | | | |
|---|------------|---|
| 6 | TYP | Select a single event type. Press once and a dash appears on the lower right of the display selecting an ON event. Press TYP key a second time to remove dash from lower right of display selecting an OFF event. Press TYP key a third time and a flashing dash appears on the lower right of display selecting a pulse (momentary contact) event. |
| 7 | E | Enters set point. |
- Repeat steps 2-7 for other set points.
- | | | |
|---|------------|-------------------------|
| 8 | RUN | Exits programming mode. |
|---|------------|-------------------------|

D. To Review Set Points

NOTE: Remember that by using the 9 key you can review set points in reverse order. For instance, if you have programmed all 50 set points and wish to review set point number 50, instead of pressing E fifty times, press 9 once to review it.

Step	Key	Description
1	PRG	Circuit number for set point number one is displayed.
2	E	Time of day, day of week, and event type for set point number one in channel one are displayed.
3	E	Circuit number for set point number two is displayed.
4	E	Time of day, day of week, and event type for set point number two are displayed.

Repeat steps 3 and 4 to review remaining set points in all four channels, until "cir" only appears (indicating no more set points are programmed.)

- 5 **RUN** Exits programming mode.

E. To Program Pulse (Momentary) Duration

NOTE: A duration must be assigned to each circuit (channel) having a momentary event.

Step	Key	Description
1	DUR	Duration is displayed for circuit 1 (i.e., "01"; one second is the default). Circuit number appears in the lower right of display.
2	CLR	Duration vanishes and two dashes appear.
3	##	Key in desired pulse duration in seconds for circuit 1.
4	E	Enters duration. Duration for circuit 2 is displayed.

Repeat steps 2-4 for circuits 2, 3 and 4.

- 5 **RUN** Exits pulse duration mode.

F. To Review Pulse Duration

Step	Key	Description
------	-----	-------------

- | | | |
|---|------------|--------------------------------------|
| 1 | DUR | Duration is displayed for circuit 1. |
| 2 | E | Duration is displayed for circuit 2. |
- Repeat step 2 for remaining channels.

3	RUN	Exits review.
---	------------	---------------

G. To Initiate Manual Override

NOTE: Program can be overridden temporarily or until the next set point. If not toggled back out of override, override will stay in effect until next set point. When circuit (channel) is overridden, LED changes status.

Step	Key	Description
------	-----	-------------

- | | | |
|---|-------------------------|------------------------------------|
| 1 | OVR | "cir" is displayed. |
| 2 | 1, 2, 3
or 4 | Override takes effect immediately. |

Repeat steps 1 and 2 to return to initial state, if desired.

3	RUN	Exits review.
---	------------	---------------

H. To Program Holiday

NOTES:

1. On programmed holidays, the special holiday schedule for each of the four circuits applies.
2. For a single day holiday, program the end month/day the same as the start month/day.
3. The E key is a forward advance key.
4. The EC74/50S has 16 holidays. Holidays may be one day or a holiday interval may be up to 366 days. The start and end dates need not be in the same calendar year. A multi-day holiday counts as a single holiday.

Step	Key	Description
------	-----	-------------

- | | | |
|---|-------------|--|
| 1 | HOL | "H.01s" (holiday #1 start) is displayed. |
| 2 | #### | Key in holiday start date (month/day). |
| 3 | E | Enters start date and "H.01E" (holiday #1 end) is displayed. |
| 4 | #### | Key in holiday end date. |
| 5 | E | Enters end date and "H.02s" is displayed. |

Repeat steps 2-5 for additional holiday durations.

6	RUN	Exits holiday mode.
---	------------	---------------------

I. To Review Holiday Dates

Step	Key	Description
1	HOL	Holiday #1 start date appears.
2	E	Holiday #1 end date appears.
Repeat step 2 for other holiday dates.		
3	RUN	Exits holiday mode.

VI. APPLICATION EXAMPLES

A. Indoor Lighting

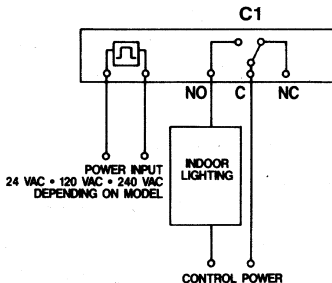

Figure 5. EC74/50S Wiring Diagram for Lighting

Objective: To control indoor lighting schedules.

Suppose you want to turn ON the lights at 7:00 A.M. and turn them OFF at 3:00 P.M. each weekday using channel 1. Suppose also that you want the lights left OFF on two holidays: Independence Day (July 4, a one-day holiday) and Christmas (December 24 and 25, a two-day holiday).

Step	Key	Description
1	PRG	"cir" is displayed (if no set points were previously programmed).
2	1	Key in circuit number.
3	E	Enters circuit number.
4	0, 7, 0, 0	Key in time for ON event.
5	2, 3, 4, 5, 6	Key in each weekday (display continues to roll through each number selected).

Step	Key	Description
6	TYP	Press key once; a dash appears on the lower right of display indicating an ON event.
7	E	Enters set point. "cir" is displayed.
8	1	Key in circuit number.
9	E	Enters circuit number.
10	0, 3, 0, 0	Key in time for OFF event.
11	PM	Dash appears on the upper right of display indicating P.M.
12	2, 3, 4, 5, 6	Key in each weekday.
13	TYP	Press key twice; dash vanishes from lower right of display indicating an OFF event.
14	E	Enters set point.
15	RUN	Exits programming mode.
16	HOL	"H.01s" (holiday #1 start) is displayed unless other holidays have been previously programmed.
17	0, 7, 0, 4	Key in first holiday start date (07/04 for July 4).
18	E	Enters start date; "H.01E" (holiday #1 end) is displayed.
19	0, 7, 0, 4	Key in first holiday end date (one day holiday).
20	E	Enters end date; "H.02s" is displayed.
21	1, 2, 2, 4	Key in second holiday start date (12/24 for December 24)
22	E	Enters start date; "H.02E" is displayed.
23	1, 2, 2, 5	Key in second holiday end date.
24	E	Enters end date (two day holiday).
25	RUN	Exits programming mode.

B. School Bell Application

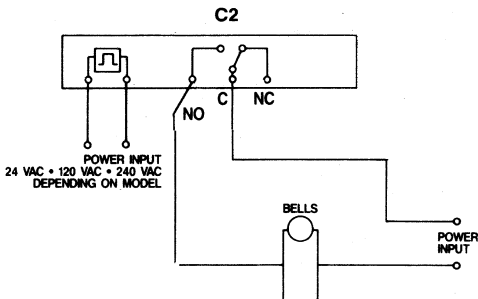

Figure 6. School Bell Wiring Diagram.

Objective: To ring school bells for three seconds on a preprogrammed schedule.

Using channel 2, suppose you want the bells to ring for three seconds on the following schedule: 7:50, 8:00, 8:50, 9:00, 9:50, 10:00.

Step	Key	Description
1	PRG	"cir" is displayed (if set points were previously programmed, press E key until "cir" appears).
2	2	Key in circuit number.
3	E	Enters circuit number.
4	0, 7, 5, 0	Key in time for first bell.
5	2, 3, 4, 5, 6	Key in weekdays (display continues to roll through each number selected).
6	TYP	Press this key three times; a flashing dash appears on the lower right of display, indicating a pulse (momentary contact) event.
7	E	Enters set point.

Repeat steps 2-7, substituting 8:00, 8:50, 9:00, 9:50, and 10:00 in step 2.

8 **RUN** Exits programming mode; time and day displayed.

Step	Key	Description
9	DUR	Duration is displayed for circuit 1.
10	E	Duration is displayed for circuit 2 ("01" unless otherwise programmed).
11	CLR	Clears duration; two dashes appear.
12	0, 3	Key in the number of seconds desired for pulse duration (a leading zero is necessary).
13	E	Enters pulse duration; displays duration for circuit 3.
14	RUN	Exits duration mode.

C. Latching Relays on Low-Voltage Lighting Application

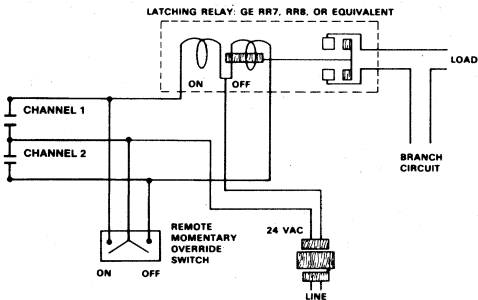

Figure 7. Latching Relay Wiring Diagram.

Objective: To operate latching relays turning ON and OFF lighting.

Suppose you want to turn ON lights at 8:00 A.M. and turn them OFF at 5:00 P.M. each week day, using channels 3 and 4 and remote latching relay or mechanical contactor. Suppose also that you want a "sweep" to turn OFF lights at 10:00 P.M. for any lights turned ON with the remote momentary override switch (shown in the diagram above). Assume pulse duration required for latching relay is two seconds.

NOTE: The latching relay configuration requires the use of two channels, one to activate the latch coil, one to activate the unlatch coil.

Step	Key	Description
1	PRG	"cir" is displayed (if no set points were previously programmed).
2	3	Key in circuit number.
3	E	Enters circuit number.
4	0, 8, 0, 0	Key in ON time.
5	2, 3, 4, 5, 6	Key in weekdays (display continues to roll through each number selected).
6	TYP	Press key three times; a flashing dash appears on the lower right of display indicating a pulse event.
7	E	Enters set point. "cir" is displayed.
8	4	Key in circuit number.
9	E	Enters circuit number.
10	0, 5, 0, 0	Key in OFF time.
11	PM	Dash appears on the upper right of display indicating P.M.
12	2, 3, 4, 5, 6	Key in weekdays.
13	TYP	Press key three times; a flashing dash appears on the lower right of display, indicating a pulse event.
14	E	Enters set point. "cir" is displayed.
15	4	Key in circuit number for "sweep."
16	E	Enters circuit number.
17	1, 0, 0, 0	Key in "sweep" OFF time.
18	PM	Dash appears on the upper right of display indicating P.M.
19	2, 3, 4, 5, 6	Key in weekdays.
20	TYP	Press key three times; a flashing dash appears on the lower right of display, indicating a pulse event.
21	E	Enters set point.
22	RUN	Exits programming mode.
23	DUR	Duration is displayed for circuit 1.
24	E	Press key twice to advance to circuit 3. "01 3" is displayed.

Step	Key	Description
25	CLR	Duration vanishes and two dashes appear.
26	0, 2	Key in pulse duration of 2 seconds.
27	E	Enters duration for circuit 3; advances to circuit 4. "01 4" is displayed.
28	CLR	Duration vanishes and two dashes appear.
29	0, 2	Key in pulse duration of 2 seconds.
30	E	Enters duration for circuit 4.
31	RUN	Exits pulse duration mode.

Troubleshooting Tips

Problem	Solution
Nothing happens when a setpoint occurs to turn a load ON or OFF.	<ul style="list-style-type: none"> • Review programmed set-points making sure the day has not been skipped. • Check input power to control. • Insure the clock is not in a holiday mode (Day 8). • Check if manual override changes the load's state (i.e. ON to OFF, OFF to ON). If it does not see next problem/solution.
Manual override does not work.	<ul style="list-style-type: none"> • Check the load for proper wiring. Remember, the EC74/50S contacts switch only what is applied to them. (Dry or isolated contacts.)
Clock display is locked up, garbled, or meaningless.	<ul style="list-style-type: none"> • Disconnect battery and input power to the control for 1 minute. Re-apply power and reprogram.
Control does not operate after programming.	<ul style="list-style-type: none"> • If programming was performed (changing clock time or entering a setpoint) the control will not update itself. Override the desired circuit until the next setpoint.

MAPLE CHASE COMPANY PRODUCT WARRANTY

The products manufactured by Maple Chase Company are warranted to be free from defects in workmanship or material under normal use and service, for a period of one (1) year from date of purchase by the user.

Maple Chase Company's obligation under this Warranty is limited to replacing, at one of its Authorized Service Centers, any part or parts of a product which shall, within the time limit set forth above, be received at one of Maple Chase Company's Authorized Service Centers with transportation charges prepaid, providing that Maple Chase Company's examination discloses to its satisfaction that such part or parts are defective.

Any adjustment or replacement of defective parts made under this Warranty does not void the Warranty; nor does it extend the original Warranty period.

The Warranty shall not extend to any Maple Chase Company product which has been tampered with or repaired by other than an Authorized Service Center of Maple Chase Company or at its factory, nor to any product which has been subject to misuse, neglect, accident or damage, or which has not been properly installed and tested in operation.

Under no circumstances shall Maple Chase Company be liable to purchaser or any third party for any loss of profits or other direct or indirect costs, expenses, losses or consequential damages arising out of or as a result of any defects in or failure of its products or any part or parts thereof.

THIS WARRANTY IS IN LIEU OF ANY OTHER WARRANTY. EITHER EXPRESSED OR IMPLIED, AS TO DESCRIPTION, QUALITY MERCHANTABILITY, FITNESS FOR ANY PARTICULAR PURPOSE OR SUE, OR ANY OTHER MATTER.

PRODUCT IMPROVEMENTS

Maple Chase Company Electric Company, Inc. reserves the right under its product improvement policy to change construction or design details without obligation regarding previous models, and furnish equipment when so altered without reference to illustrations or specifications used herein.



Maple Chase Company
2820 Thatcher Road
Downers Grove, Illinois 60515
Made in Mexico

An Invensys company

Telephone + 1 800 732 8400

ISO 9002 registered