

EC71/18S and EC71D/18S
365-Day Single Channel Time Controls
General Instructions



CONTENTS

INTRODUCTION	.3
SPECIFICATIONS	.4
INSTALLATION	.8
CONTROL DESCRIPTION	.15
PROGRAMMING	.17
APPLICATIONS	.27
TROUBLESHOOTING TIPS	.33

I. INTRODUCTION

The EC71/18S and EC71D/18S are 365-day single channel, microprocessor-based time controls. They are used for switching electrical circuits according to a pre-set time program. These controls are ideal for use with lighting, heating, ventilating, air conditioning, motors, pumps, fans, bells, security systems, traffic intersection lights, school flashers, or any load with a time-of-day schedule. The programmable momentary option provides a 1 to 59 second momentary contact closure for such applications as ringing school bells, church chimes, and operating latching relays.

II. SPECIFICATIONS

PROGRAMMING CAPABILITIES

- Seven-day programming using 365-day calendar with an eighth day as a holiday program.
- 11 holiday durations programmable by date.
- Control may be programmed with up to 18 setpoints. A setpoint is an event at a certain time of day, assignable to any day or to any combination of days.
- Each setpoint can be either an ON, OFF or momentary type event. A programmable momentary duration of 1-59 seconds can be entered.
- 12-hour (AM/PM) or 24-hour clock format.
- Automatic daylight-saving time changeover.
- Keyboard override until next programmed event.
- Leap year corrected to the year 2100.
- Keyboard programming.
- LCD display of time of day and day of week.

ELECTRICAL: Power Requirements**EC71D/18S**

VOLTAGE	HERTZ	VA REQ.
24 Vac (+10 -15%)	50/60	4
100-120 Vac	50/60	4
200-240	50/60	4

EC71/18S

100-120 Vac	50/60	4
-------------	-------	---

Output - One SPDT output relay rated as follows:

EC71D/18S

VOLTAGE	RESISTIVE	INDUCTIVE	PILOT DUTY
24 Vac	15A	15A	60 VA
120 Vac	15A	15A	345 VA
240 Vac	10A	8A	450 VA

EC71/18S

120 Vac	15A	15A	345 VA
---------	-----	-----	--------

Wiring - Terminals can accommodate 12 to 24 AWG wire.

POWER OUTAGE CARRYOVER

Program and Time-of-Day Backup - 100 hours of carryover with an alkaline 9 volt battery (not provided).

These controls are completely operational during a power outage, except for relay operation.

ACCURACY

Time-of-Day - Maintained time is as accurate as line frequency.

Resolution - One minute for time-of-day and programmed ON and OFF events. (One second resolution using momentary type event.)

PHYSICAL

- Mounting**
- EC71D/18S: Surface or DIN-rail (35MM, DIN-EN50022) mounting with plug-in base.
 - EC71/18S: NEMA type 1 enclosure.

- Weight**
- EC71D/18S: Approximately 1 lb. 3 oz. (0.54 kg).
 - EC71/18S: Approximately 4 lbs. (1.8 kg).

Dimensions

- EC71D/18S:
 - Width: 4.1 in. (10.5 cm)
 - Height: 4.0 in. (10.2 cm)
 - Depth: 3.0 in. (7.5 cm)

- EC71/18S:
 - Width: 4.1 in. (10.5 cm)
 - Height: 7.9 in. (20.1 cm)
 - Depth: 3.0 in. (7.5 cm)

III. INSTALLATION INSTRUCTIONS

Mount the control in an environment that is free from excessive contaminants such as oil, moisture or dirt.

EC71D/18S MOUNTING

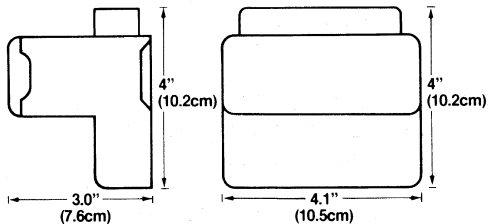

Figure 1. Dimensions of EC71D/18S

DIN Rail Mounting:

1. Remove back mounting plate by releasing spring loaded catch. See Figure 2.
2. Snap base connection block onto DIN-rail.

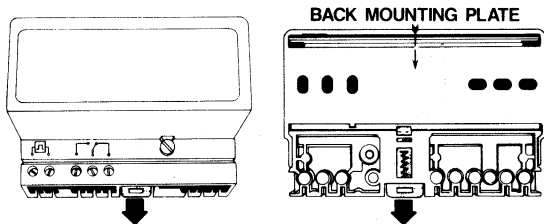

Figure 2. Spring Loaded Catch

Surface Mounting:

1. Remove back mounting plate by releasing spring loaded catch. See Figure 2.
2. Install back mounting plate in a horizontal position on a vertical or horizontal surface using the mounting holes provided.
3. Snap control onto back mounting plate.

EC71/18S CASE MOUNTING

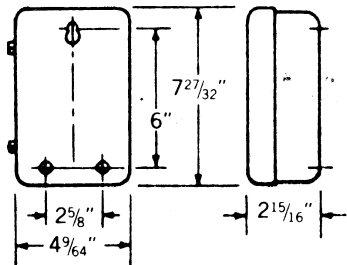

Figure 3. EC71/18S Dimensions

1. Remove control from case by pressing spring clip at right center of case and lift control out.
2. Mount case in a vertical position using mounting holes provided (see Figure 3.)
3. Replace control into case by inserting tabs on the left side of front panel into holes in side of case. Push down and snap into place.
4. Connect an electrical ground to grounding screw terminal.

WIRING:

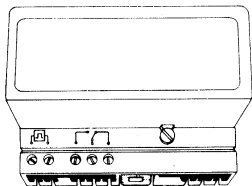

Figure 4. EC71D/18S Input and Output Terminals

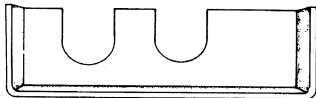

Figure 5. EC71D/18S Terminal Cover Cut-Out

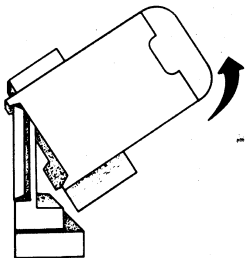

Figure 6.

Side view of EC71D/18S (If the unit malfunctions, the plug-in case allows easy removal of the unit from the terminal block without disturbing the wiring. After loosening the terminal cover screw, it is possible to swing the case upwards.)

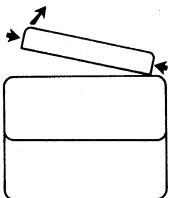

Figure 7. Removal of EC71D/18S Battery Cover

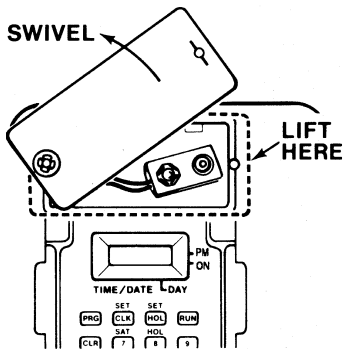
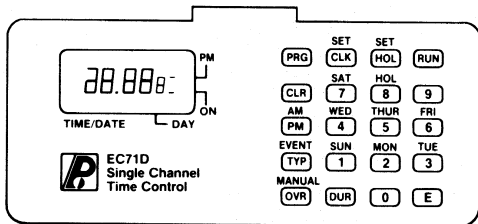

Figure 8. Removal of EC71/18S Battery Cover

For EC71D/18S (DIN mountable) units only: Loosen terminal cover screw and set terminal cover aside. The screw is captive to the control. Wiring access for power input and relay output is provided at bottom of terminal block.

1. Wire 24, 120 or 240 Vac input to terminals for the EC71D/18S model selected. Wire 120 Vac to input terminals for the EC71/18S. Terminals can accommodate 12 to 24 AWG wire. CAUTION: Damage will occur to unit if incorrect voltage is applied. Application of incorrect input voltage will void warranty.
2. Connect output wiring as required for the particular application.
3. For EC71D/18S, cut out terminal cover for wiring; replace terminal cover and tighten terminal screw (see Figure 5).
4. Install a 9V alkaline battery (not provided). Remove battery cover (see Figure 7 or 8). Snap battery into battery clip. Replace battery cover.
5. Maintenance - This time control has been carefully engineered for reliability and safety; therefore, the only maintenance required is to replace the 9V battery approximately every two years. A battery log is provided to write down battery replacement dates. Do not use any type of cleaning agent on the liquid crystal display or the front panel.



IV. CONTROL DESCRIPTION

FRONT PANEL

1. Time/Date Indicator - Displays hours and minutes in 12/24 hour format (for example, 00:00 = midnight, 12:00 = noon) or month and date for current day or an event being programmed or reviewed.

Day of Week Indicator - Displays current day of week or day being programmed.
(Sunday = 1, Monday = 2, Saturday = 7)
2. Mode Keys - PRG (program), CLK (clock), HOL (holiday), DUR (duration) used to select mode of operation.

3. Number/Day Keys - Used to set or program time, day, month, date and year.
4. Clear Key - Must be used to clear an old entry before a new one may be entered and to clear keying errors.
5. AM/PM Key - Used to select 12-hour clock format and AM or PM in program and clock modes.
6. Event TYP (type) Key - Used to select, ON, OFF or momentary event type.
7. Manual OVR (override) Key - Used to toggle relay state until next event.
8. DUR (duration) Key - Used to program length of momentary pulses.
9. E (enter) Key - Used to enter a new setpoint and advances to allow review of program.

V. PROGRAMMING INSTRUCTIONS

The EC71/18S is easy to program. The sequence outlined here is the logical order of programming. First, you will want to program the time-of-day, day of week, date and year. Then you can program setpoints according to your application (refer to Application Examples, Section VI for sample programming).

Notes:

1. When the unit is first powered, the display will show "24 Hr." Press the Enter key to select 24-hour format. Press the AM/PM key to select 12-hour format. (The display will show time of day with the colon flashing.)
2. A leading zero must be used when hours, minutes, month or date are less than ten.
3. The day of week is displayed as follows: 1 = Sunday, 2 = Monday, 3 = Tuesday, 4 = Wednesday, 5 = Thursday, 6 = Friday, 7 = Saturday and 8 = Holiday.
4. In all programming modes, if a keying error is made, press CLR key then reprogram entire sequence of number keys.
- 5.

<u>24-Hour Clock Time</u>	<u>12-Hour Clock Time</u>	<u>24-Hour Clock Time</u>	<u>12-Hour Clock Time</u>
0:00	12:00 AM (Midnight)	12:00	12:00 PM (Noon)
1:00	1:00 AM	13:00	1:00 PM
2:00	2:00 AM	14:00	2:00 PM
3:00	3:00 AM	15:00	3:00 PM
4:00	4:00 AM	16:00	4:00 PM
5:00	5:00 AM	17:00	5:00 PM
6:00	6:00 AM	18:00	6:00 PM
7:00	7:00 AM	19:00	7:00 PM
8:00	8:00 AM	20:00	8:00 PM
9:00	9:00 AM	21:00	9:00 PM
10:00	10:00 AM	22:00	10:00 PM
11:00	11:00 AM	23:00	11:00 PM

A. TO PROGRAM TIME-OF-DAY, DAY-OF-WEEK, DATE AND YEAR

Step	Key	Description
1	CLK	Time and day of week on display vanish and dashes appear for each digit.
2	#####	Key in time and day of week. If in 12-hour clock format, and in PM hours, press PM key; dash will appear at far right of display.
3	E	Enters time and day of week. Default day of January 1 appears.
4	CLR	Date vanishes and dashes appear for each digit.
5	####	Key in date. (Month is first and day is second in both 12-hour and 24-hour mode.)
6	E	Date is entered. Latest or default year is displayed.
7	CLR	Clears year.
8	##	Key in current year. Two keys must be pressed (i.e., "86").

- 9 **E** Enters year. "SPr" appears (spring daylight-saving time)
- 10 **###** Key in day (month/day) of spring daylight-saving time, if desired. (If not desired, proceed with step 11).
- 11 **E** Enters spring date. "FaLL" appears (fall daylight-saving time).
- 12 **####** Key in date of fall daylight-saving time, if desired. (If not desired, proceed with step 13).
- 13 **E** Enters fall date. Control returns to RUN mode.

B. TO REVIEW DATE AND YEAR

Step	Key	Description
1	CLK	Dashes appear for time and day of week
2	E	Month and day appear.
3	E	Year appears
4	E	Date of spring daylight-saving time appears.
5	E	Date of fall daylight-saving time appears.

C. TO PROGRAM SETPOINTS

The EC71/18S offers three event choices: ON, OFF or pulse (momentary contact) event.

Notes:

1. A setpoint can be assigned to any single day or to any combination of days.
2. The E key enters the programming and serves as forward advance key.

Step	Key	Description
1	PRG	Dashes are displayed.
2	####	Key in time (and AM/PM if necessary).
3	#	Key in day(s) of week and holiday if desired. If more than one day is desired, key in additional days. (Days programmed will flash on display in sequence.)

Note: A previously entered day can be removed by pressing the appropriate day key.

- 4 **TYP** A dash appears on the lower right of the display, indicating an ON event. Press TYP key a second time to remove dash from lower right of display, indicating an OFF event. Press TYP key a third time and a flashing dash appears on the lower right of display, indicating a pulse (momentary contact) event.
- 5 **E** Enters setpoint.
- Repeat steps 2-5 for other setpoints.
- 6 **RUN** Exits programming mode.

D. TO PROGRAM PULSE (Momentary) DURATION

- | Step | Key | Description |
|-------------|------------|---|
| 1 | DUR | Duration is displayed (i.e. "01", one second is the default). |
| 2 | CLR | Duration vanishes and two dashes appear. |

- | | | |
|---|-----------|---|
| 3 | ## | Key in desired pulse duration in seconds. |
| 4 | E | Enters duration. Exits pulse duration mode. |

E. TO INITIATE MANUAL OVERRIDE

Note: Program can be overridden until the next setpoint. If not toggled back out of override, override will stay in effect until next setpoint.

Step	Key	Description
1	OVR	Override takes effect immediately.

F. TO REVIEW SETPOINTS

Step	Key	Description
1	PRG	Time of day, day of week and event type for setpoint number one are displayed.
2	E	Time of day, day of week and event type for setpoint number two are displayed.

Repeat step 2 for remaining setpoints

3	RUN	Exits programming mode.
---	------------	-------------------------

G. TO PROGRAM HOLIDAY

Notes:

1. For a single day holiday, program the end month/day the same as the start month/day.
2. The E key is a forward advance key.
3. A holiday interval may be up to 366 days. The start and end dates need not be in the same calendar year.

Step	Key	Description
1	HOL	"H.01s" (holiday #1 start) is displayed.
2	####	Key in holiday start date (month/day).
3	E	Enters start date and "H.01E" (holiday #1 end) is displayed.
4	####	Key in holiday end date.
5	E	Enters end date and "H.02s" is displayed.
Repeat steps 2-5 for additional holiday durations.		
6	RUN	Exits holiday mode

H. TO REVIEW HOLIDAY DATES

Step	Key	Description
1	HOL	Holiday #1 start date appears.
2	E	Holiday #1 end date appears.

Repeat step 2 for other holiday dates.

3	RUN	Exits holiday mode.
---	------------	---------------------

VI. APPLICATION EXAMPLES

A. Indoor Lighting

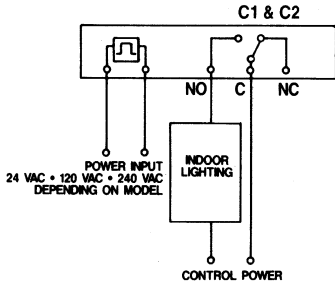

Figure 10. EC71/18S Wiring Diagram for Lighting

Objective: To control indoor lighting schedules.

Suppose you want to turn ON the lights at 8 a.m. and turn them OFF at 5 p.m. each weekday. Suppose also that you want the lights left OFF on two holidays: Independence Day (July 4, a one day holiday) and Christmas (December 24 and 25, a two day holiday).

Step	Key	Description
1	PRG	Dashes are displayed.
2	0,8,0,0	Key in time for ON event.
3	2,3,4,5,6	Key in each weekday (display continues to roll through each number selected).
4	TYP	Press key once; a dash appears on the lower right of display indicating an ON event.
5	E	Enters setpoint.
6	0,5,0,0	Key in time for OFF event.
7	PM	Dash appears on the upper right of display indicating p.m.
8	2,3,4,5,6	Key in each weekday.
9	TYP	Press key twice; dash vanishes from lower right of display indicating an OFF event.

- 10 **E** Enters setpoint.
- 11 **RUN** Exits programming mode.
- 12 **HOL** "H.01s" (holiday #1 start) is displayed
 unless otherwise programmed.
- 13 **0,7,0,4** Key in first holiday start date (07/04 for July 4).
- 14 **E** Enters start date; "H.01E" (holiday #1 end)
 is displayed.
- 15 **0,7,0,4** Key in first holiday end date (one day holiday).
- 16 **E** Enters end date; "H.02s" is displayed.
- 17 **1,2,2,4** Key in second holiday start date
 (12/24 for December 24).
- 18 **E** Enters start date; "H.02s" is displayed.
- 19 **1,2,2,5** Key in second holiday end date.
- 20 **E** Enters end date (two day holiday).
- 21 **RUN** Exits programming mode.

B. School Bell Application

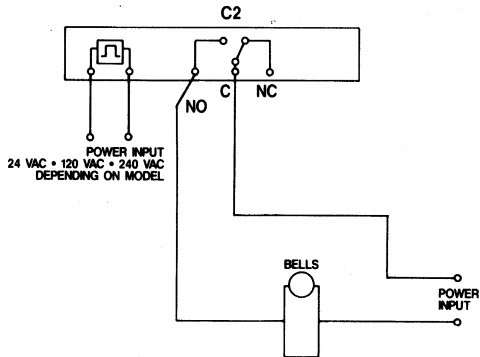

Figure 11. School Bell Wiring Diagram

Objective: To ring school bells for 3 seconds on a preprogrammed schedule.

Suppose you want the bells to ring for three seconds on the following schedule: 7:50, 8:00, 8:50, 9:00, 9:50, 10:00.

Step	Key	Description
1	PRG	Dashes displayed.
2	0,7,5,0	Key in time for first bell.
3	2,3,4,5,6	Key in weekdays (display continues to roll through each number selected).
4	TYP	Press this key three times; a flashing dash appears on the lower right of display, indicating a pulse (momentary contact) event.
5	E	Enters setpoint. (Repeat steps 2-5, substituting 8:00, 8:50, 9:00, 9:50, and 10:00 in step 2).
6	RUN	Exits programming mode; time and day displayed.

- | | | |
|----|------------|--|
| 7 | DUR | Duration is displayed ("01" unless otherwise programmed). |
| 8 | CLR | Clears duration; two dashes appear. |
| 9 | 0,3 | Key in the number of seconds desired for pulse duration (a leading zero is necessary). |
| 10 | E | Enters pulse duration; exits pulse duration mode. |

TROUBLESHOOTING TIPS

Nothing happens when a set-point occurs to turn the load on or off.

Manual override does not work.

Clock display is locked up, garbled, or meaningless.

Blank Display

Control does not operate after programming.

- Review the programmed setpoints. Remember a bar = an ON event, flashing bar = MOMENTARY event.
- Insure that each day is programmed when the event is to occur.
- Check to make sure the control is not in a holiday period.
- Check if manual override changes the load's state. If it does not, see next problem/solution.
- Check the load for proper wiring. Remember the EC71/18S contacts, only switch what is applied. (Dry or isolated contacts.)
- Disconnect battery and input power to clock for 1 minute. Re-apply power and reprogram.
- Check input power source and battery if installed. Insure proper connection.
- If programming was performed (changing clock time or entering a setpoint) the control will not update itself. Press the OVR key and override the load until the next scheduled setpoint

PARAGON PRODUCT WARRANTY

The products manufactured by Paragon Electrical Products are warranted to be free from defects in workmanship or material under normal use and service, for a period of one (1) year from date of purchase by the user.

Paragon's obligation under this Warranty is limited to replacing, at one of its Authorized Service Centers, any part or parts of a product which shall, within the time limit set forth above, be received at one of Paragon's Authorized Service Centers with transportation charges prepaid, providing that Paragon's examination discloses to its satisfaction that such part or parts are defective.

Any adjustment or replacement of defective parts made under this Warranty does not void the Warranty; nor does it extend the original Warranty period.

The Warranty shall not extend to any Paragon product which has been tampered with or repaired by other than an Authorized Service Center of Paragon or at its factory, nor to any product which has been subject to misuse, neglect, accident or damage, or which has not been properly installed and tested in operation.

Under no circumstances shall Paragon be liable to purchaser or any third party for any loss of profits or other direct or indirect costs, expenses, losses or consequential damages arising out of or as a result of any defects in or failure of its products or any part or parts thereof.

THIS WARRANTY IS IN LIEU OF ANY OTHER WARRANTY, EITHER EXPRESSED OR IMPLIED, AS TO DESCRIPTION, QUALITY MERCHANTABILITY, FITNESS FOR ANY PARTICULAR PURPOSE OR USE, OR ANY OTHER MATTER.

PRODUCT IMPROVEMENTS

Paragon Electrical Products reserves the right under its product improvement policy to change construction or design details without obligation regarding previous models, and furnish equipment when so altered without

reference to illustrations or specifications used herein.



Maple Chase Company
2820 Thatcher Road
Downers Grove, Illinois 60515
Made in Mexico

110-702

Telephone + 1 630 719 5500
Facsimile + 1 630 719 4400

ISO 9002 registered



A Kobe Group Company